



BRAMBLE

PRODUCT TEARSHEET



# Emerson 2 Drawer Filing Cabinet

---

Shown in: **BRS**

SKU: **23655**

Size: **20W x 18D x 30H in**



## Overview

---

Accent the room with this tasteful Emerson Two Drawer Filing Cabinet. Made from rich mahogany wood, this wonderful filing cabinet has two beautifully crafted dovetail drawers and can also be used as an eye-catching accent to the room. This piece is offered with a vast array of finish and distress options to create a truly custom design.

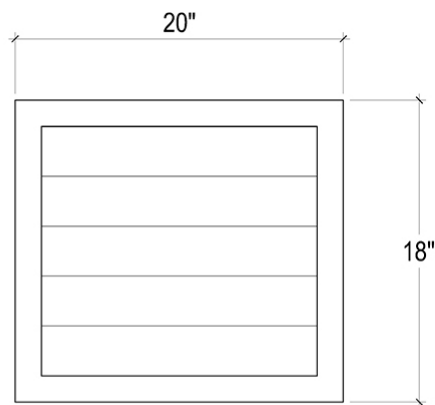

TOP VIEW

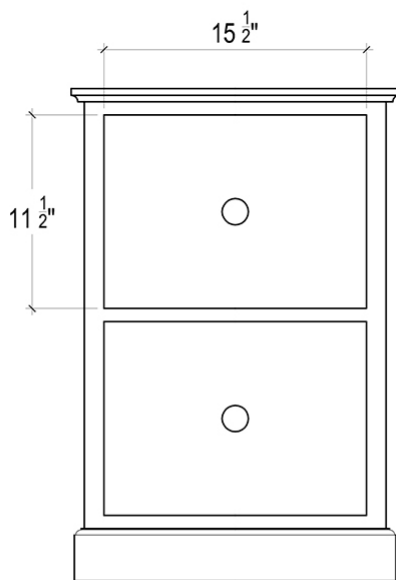

FRONT VIEW

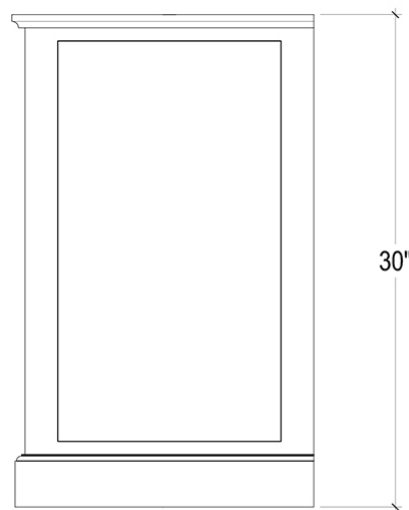

SIDE VIEW

## Visual Highlights

---



## Technical Specification

---

Dimensions	<b>20W x 18D x 30H in</b>	CBM	<b>0.197334</b>
Number of Packages	<b>1</b>	Cubic Feet	<b>6.97 ft<sup>3</sup></b>
Package 1 Dimensions	<b>21.3 x 19.7 x 32.3 in</b>	Package 1 Weight	<b>46.3 lbs</b>
Package Weight Total	<b>46.3 lbs</b>	Net Weight	<b>35.27 lbs</b>
Material	<b>Mahogany</b>		

<https://brambleco.limecommerce.com/23655>

---