



BRAMBLE

PRODUCT TEARSHEET



Fulham Linen Wrapped Nightstand

Shown in: **FPUT**

SKU: **76583**

Size: **19W x 15D x 26H in**



Overview

Fulham Nightstand

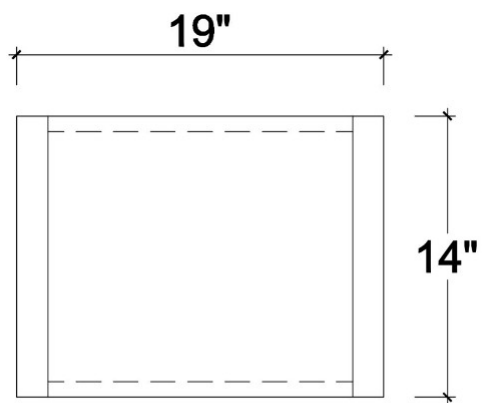

TOP VIEW

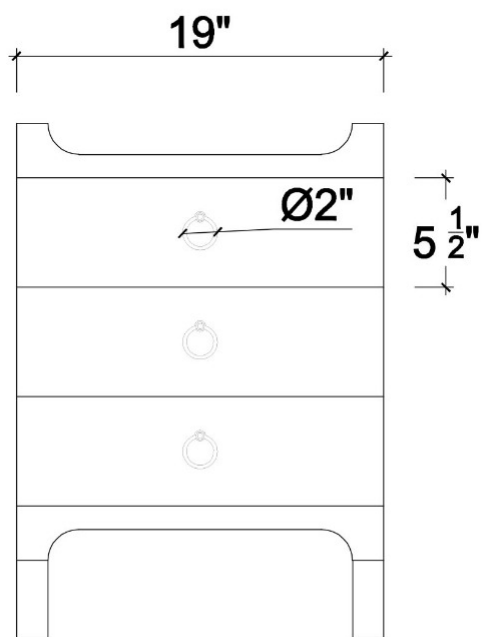

FRONT VIEW

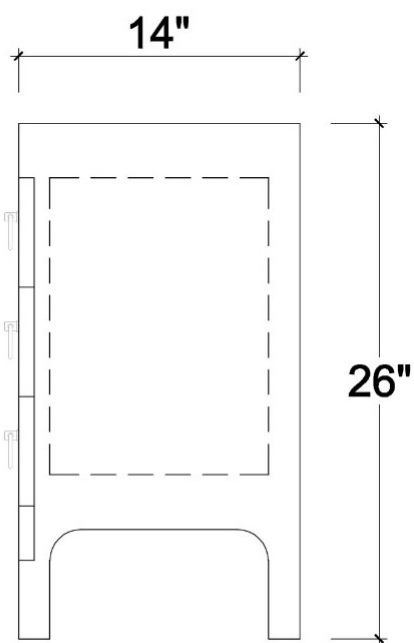

SIDE VIEW

Visual Highlights

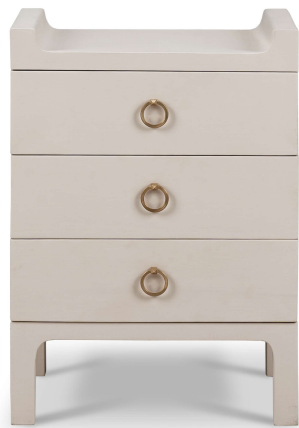

Technical Specification

Dimensions	19W x 15D x 26H in	CBM	0.16
Number of Packages	1	Cubic Feet	5.65 ft³
Package 1 Dimensions	20.1 x 16.5 x 28.7 in	Package 1 Weight	38.58 lbs
Package Weight Total	38.58 lbs	Net Weight	35.27 lbs
Material	Mahogany, Rattan, Fabric		

<https://brambleco.limecommerce.com/76583>
