

EST. *B* 1991

BRAMBLE

PRODUCT TEARSHEET



Tractor Barstool

SKU: **FAC-25855STW-----**

Size: **18W x 17D x 33H in**



Overview

Reflecting a whimsical design, the Tractor Barstool delivers a fun and fashionable pairing for a casual kitchen counter or pub table. Crafted from solid mahogany, its seat mimics a tractor design and infuses a hint of farmhouse appeal. This piece is offered with a vast array of finish and distress options to create a truly custom design.

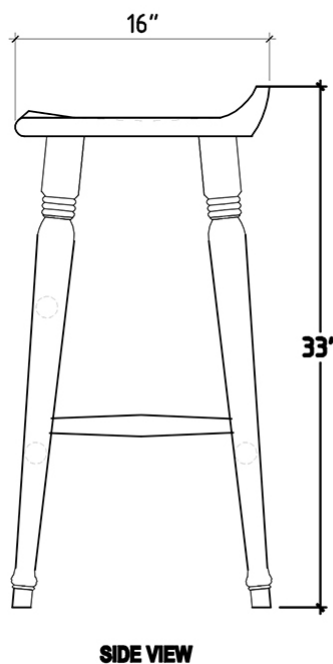
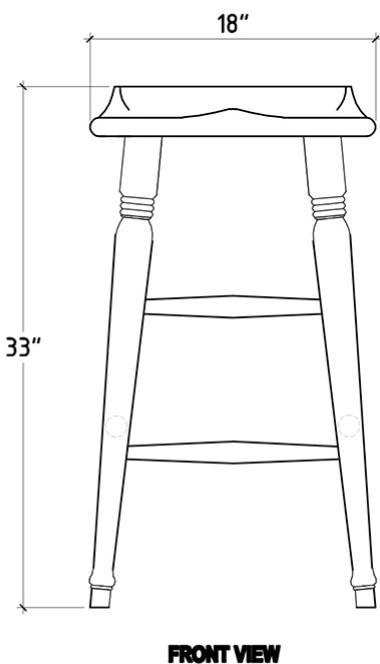
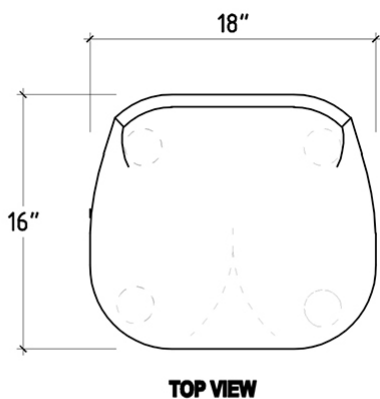

Technical Specification

Dimensions	18W x 17D x 33H in	CBM	0.186688625
Number of Packages	1	Cubic Feet	6.59 ft³
Package 1 Dimensions	19.7 x 18.1 x 35.8 in	Package 1 Weight	28.66 lbs
Package Weight Total	28.66 lbs	Net Weight	22.05 lbs

Factory
Ready
Stock

<https://brambleco.limecommerce.com/fac-25855stw>
